

AL-HPW-TF1
LED Vapor Tights

Features

- The Abaco Lighting AL-HPW-TF1 is designed to provide exceptional light output and energy efficiency in demanding environments that require watertight seals
- IP67 Rated - Dust and liquid protected.
- UL Listed for wet location
- DesignLights Consortium qualified
- Five Year Warranty

Applications

- Food and beverage processing and preparations
- Cold storage facilities
- Warehouse / Distribution centers
- Manufacturing facilities
- High Bay / Low Bay
- Flood light
- Parking garages
- Gymnasium / Natatoriums

Electrical

- Input: 100~277 VAC, 50/60Hz
- Power Factor: >95%
- THD < 15% at full load
- Power: 120W, 160W, 180W
- Replaceable LED Modules
- Ambient Temperature Range: -40°C to 55°C
- Surge Protection: 4KV
- LED life span(L70): >100,000hrs.

Housing

- Die Cast, resistance to corrosion, ultraviolet, degradation and abrasion
- Aluminum alloy body
- Anodized and Powder Coated to create a durable and resistant finish
- Stainless steel bracket and hardware
- Available in White or Bronze

Certifications

DESIGNLIGHTS
 CONSORTIUM

Photometric

- Philips™ LumiLeds
- L70 calculated 100,000 hours
- Luminaire efficiency rating 105 lm/W
- Color rendering index (CRI) >70

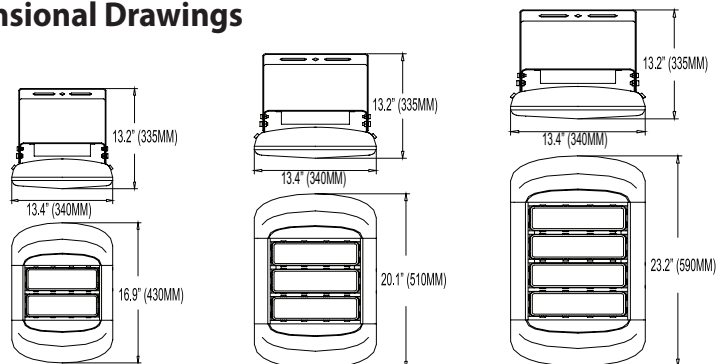
Dimensional Drawings

Packaging Size: 20.5" X 16.9" X 9.1"

23.6" X 16.9" X 9.1"

26.8" X 16.9" X 9.1"

Weight: 6.3Kgs (13.86lbs)

7.3Kgs (16.06lbs)

8.3Kgs (18.26lbs)

Ordering Guide

Series	Wattage - Lumen Output	CCT	Driver	Options
AL-HPW-TF1	120: 120W - 11,400	5: 5000K	U: 120~277V	CORD: Power Cord Whip PLUG: (Specify)
	160: 160W - 16,800			
	180: 180W - 17,100			

Adding an Abaco Lighting approved motion sensor system to your lighting upgrade project will further enhance energy savings and create an even faster payback. Specifications are subject to change with or without notice.