

WLXTE & CWLXTE: Wet Location LED Exit/Incandescent Emergency Combo

Project:	
Type:	
Catalog #:	



Features

- UL listed for wet locations & meets UL924, NFPA 101 Life Safety Code, NEC, OSHA, Local and State Codes
- Fully gasketed, corrosion-resistant housing
- Energy efficient LED technology in EXIT sign
- EZ snap-out chevron directional indicators

Electrical

- Dual 120V/277V voltage
- Charge rate/power "ON" LED indicator light and push-to-test switch for mandated code compliance testing
- LVD (low voltage disconnect) prevents battery from deep discharge
- Long-life, maintenance-free, rechargeable NiCd battery (EM models)
- Internal solid-state transfer switch automatically connects the internal battery to LED Board/lamp heads for minimum 90-minute emergency illumination
- Fully automatic solid-state, two-rate charger initiates battery charging to recharge a discharged battery in 24 hours.

Mounting

- Knockouts for back mounting

Housing

- Corrosion-resistant, polycarbonate UV-stabilized housing
- Removable KO directional indicators
- Single face only
- Polycarbonate face plate

Options

- Using the optional internal heater (-HTR) enables the unit to be used in cold environments (contact customer service for more information).

Illumination

- Standard with two 5.4 watt tungsten, adjustable, glare-free lighting heads
- High-performance reflector and tempered glass lens for optimal light distribution.
- Ultra bright, energy efficient, long-lasting Red or Green LED (exit sign illumination)
- 6" EXIT letters

Warranty

- Five Year Warranty on all electronics and housing. Batteries are pro-rated warranted for 5 years.

Dimensions

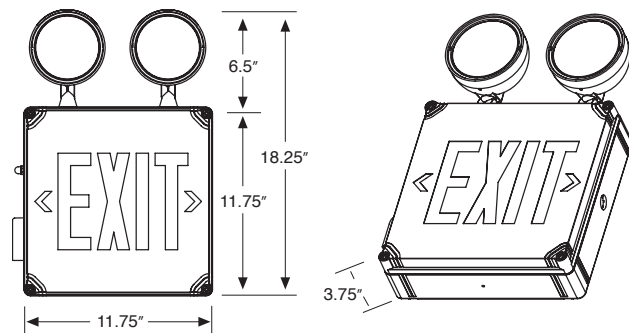

ORDERING INFORMATION

Model	Letter Color	Battery	Options
WLXTE	R - Red	Blank - AC Only	HTR - Internal Heater
	G - Green	EM - NiCad Battery Backup	
CWLXTE	R - Red	EM - NiCad Battery Backup	HTR - Internal Heater
	G - Green		

Model	Letter Color	Battery	Options
-	-	-	-

