

AL-HOX Series
LED High Bay

Features

- Replaces up to 1000W MH or HPS
- Designed for mounting heights of 40 feet or higher
- L90 at 70,000 hours
- L70 predicted life is more than 200,000 hours
- Dry/Damp interior applications (IP30)
- 5 Year limited warranty / 7-Year Warranty Available

Applications

- Airport Hangars
- Warehouse
- Manufacturing
- Gymnasiums

Certifications

Fixture Details

Model Name	HOX-500	HOX-750	HOX-1000
Power Consumption	293W	440W	586W
Luminous Efficacy	> 104.8 lm/W	> 104.7 lm/W	> 104.8 lm/W
Luminous Flux	30,700 lm	46,050 lm	61,400 lm
Color Temperature	4000K, 5000K		
Color Rendering	> 75 CRI		
Beam Angle	120° Symmetric		
Life Time Rating	L90 at 70,000 hours, L70 at > 200,000 Hours		
Input Voltage	120 - 277 VAC, 347 - 480 VAC		
Frequency	50 / 60Hz (47 - 63Hz)		
Operation Temperature	-31 °F - 131°F (-35 °C - 55 °C)		
Size (W x L x H)	22 7/8" x 22" x 17"	22 7/8" x 22" x 17"	22 7/8" x 22" x 17"
Weight	19lbs (8.6Kg)	21lbs (9.5Kg)	23lbs (10.4Kg)
Body	Cast and brazed aluminum		
Optic	Tempered, low iron 3mm glass		
Warranty	5-Year limited warranty / 7-Year warranty available		
IP Rating	IP30		
Mounting Options	Hook, pendant		
Dimming Options	Optional 10-100% dimming controlled with a 0-10V Dimmer		

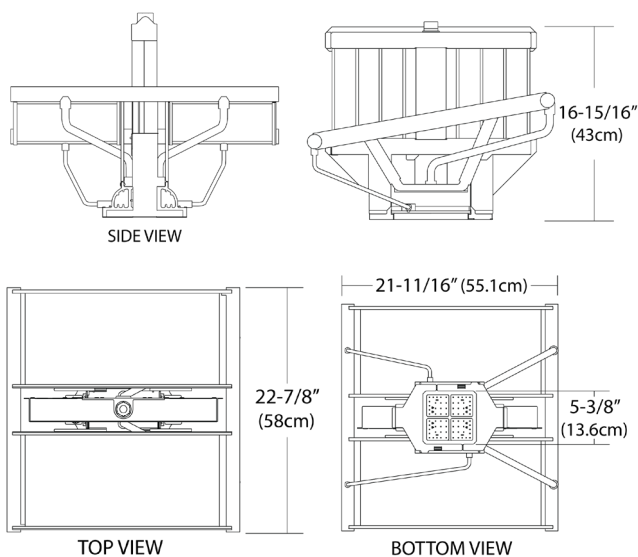
Dimensional Drawings

Ordering Guide

Series	Wattage	CCT	Driver	Options
AL-HOX	500: 293W	4: 4,000K	U: 120 - 277V	DIM: 0 - 10V Dimming
	750: 440W	5: 5,000K	HV: 347 - 480V	HCP: Hook, cord and Plug
	1000: 586W			CAT: Cover Accessory Kit

Adding an Abaco Lighting approved motion sensor system to your lighting upgrade project will further enhance energy savings and create an even faster payback. Specifications are subject to change with or without notice.