

RMR-16WP: Wet Location Emergency Light with MR-16 Halogen Lamp Heads

Project:	
Type:	
Catalog #:	



Features

- Compact, low-profile design in neutral finish
- Fully-gasketed polycarbonate enclosure provides resistance to corrosive atmospheres and non-hazardous environments
- UL listed for wet locations & meets UL924, NFPA 101 Life Safety Code, NEC, OSHA, Local and State Codes

Electrical

- Dual 120V/277V voltage
- Charge rate/power "ON" LED indicator light and push-to-test switch for mandated code compliance testing
- LVD (low voltage disconnect) prevents battery from deep discharge
- 6V, 4.5Ah, sealed lead acid, maintenance-free, rechargeable battery
- Internal solid-state transfer switch automatically connects the internal battery to lamp heads for minimum 90-minute emergency illumination
- Fully automatic solid-state, two-rate charger initiates battery charging to recharge a discharged battery in 24 hours

Mounting

- Surface mount via easy connect back plate

Housing

- Injection-molded, engineering-grade, V-0 flame retardant, high-impact, thermoplastic in neutral gray finish
- Fully-gasketed clear polycarbonate cover offers protection against wet, non-hazardous dust, and hose-down locations

Illumination

- Two adjustable, ultra-bright, round 6V, 7W MR-16 halogen lighting heads

Options

- Using the optional internal heater (-HTR) enables the unit to be used in cold environments (contact customer service).

Warranty

- Five Year Warranty on all electronics and housing. Batteries are pro-rated warranted for 5 years.

Dimensions

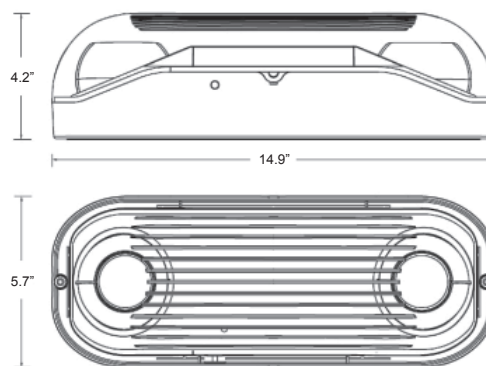

ORDERING INFORMATION

Model	Color	Options
RMR-16WP	G - Gray	HTR - Internal Heater

Model	Color	Options
-------	-------	---------

